

Single Window for Trade Facilitation: Japan's Experience

22 October 2024

Customs and Tariff Bureau,
Ministry of Finance, Japan



NACCS : Nippon Automated Cargo and Port Consolidated System

NACCS is a system which is jointly used by the public and private sectors, and which electronically processes administrative procedures, that is: Customs procedures, Import/Export-related procedures (Food Quarantine, Animal/Plant Quarantine and Trade Control) and Port-related procedures (Arrival/Departure Procedures), as well as private procedures such as transportation and storage.

NACCS is managed and operated by a private company, NACCS Center.

About NACCS Center

Purpose of NACCS Center Inc.

NACCS Center Inc. is a stock company that operates and manages NACCS to ensure speedy and accurate import/export related operations.

Scope of business of NACCS Center Inc.

- ▶ Operate and manage NACCS that processes import/export business
- ▶ Develop and store program/data of NACCS
- ▶ Operate incidental business to operating NACCS



In operating the above business, NACCS Center strives for providing customers with its national service at as low a fee as possible by effective and efficient corporate management.

-Stipulated by NACCS Law

Government involvement

▶ To ensure the fair and stable operation of NACCS, government is requested to be constantly involved in the management of NACCS Center Inc. through its authority as stipulated by the Law.

- ▶ Authorization of articles of incorporation, annual business plan
- ▶ Supervision, inspection of business activity
- ▶ Voting right as stockholder

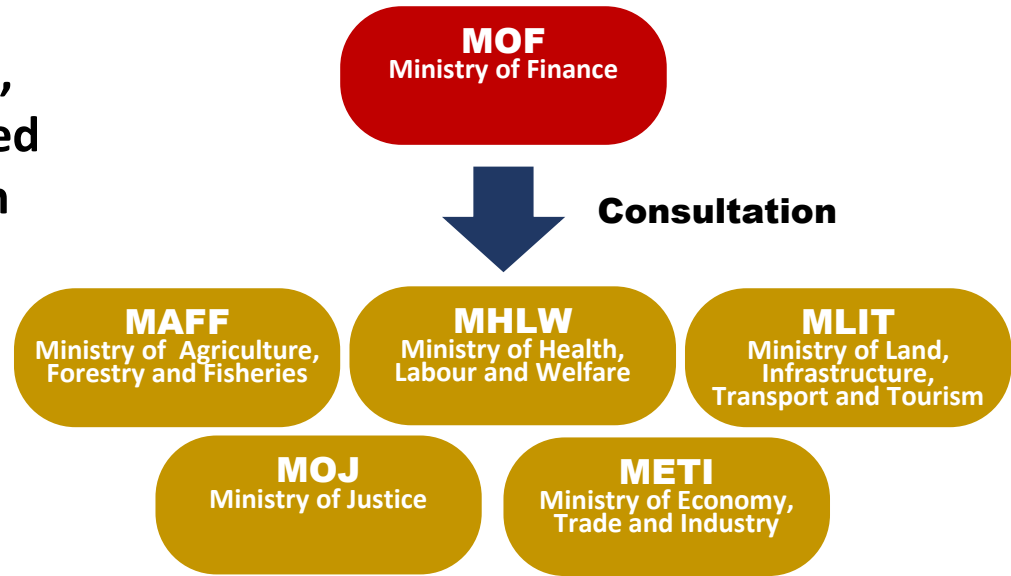

Import/Export-related Procedures

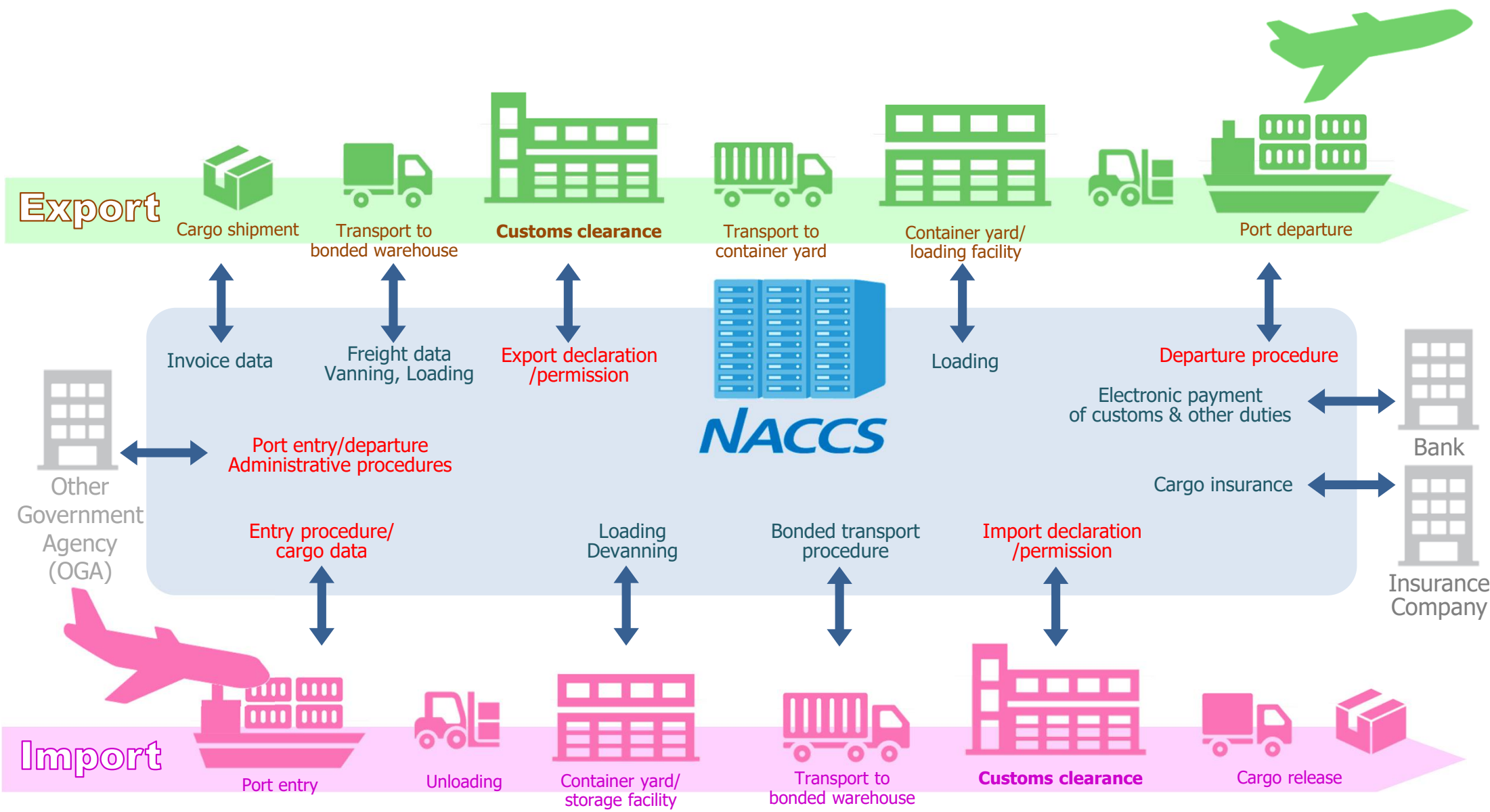

History of NACCS



Air-NACCS

1978: Version.1 started its service for import air cargo
1985: Version.2 extended operation to export air cargo

1993: Version.3 extended operation to arrival/departure procedures
2001: Version.4 expanded its function



Sea-NACCS

1991: Version.1 started its service for import/export cargo
1999: Version.2 expanded its function
2008: Version.3 expanded its function

2010: Integrated NACCS (Version.5) was put into operation

2024: Version.6 of NACCS (Since October of 2017)

2025: Version.7 of NACCS will start operating

First Generation (From Apr. 1997, Jul. 2003)

Simple Interfacing SW System
Less User Friendly

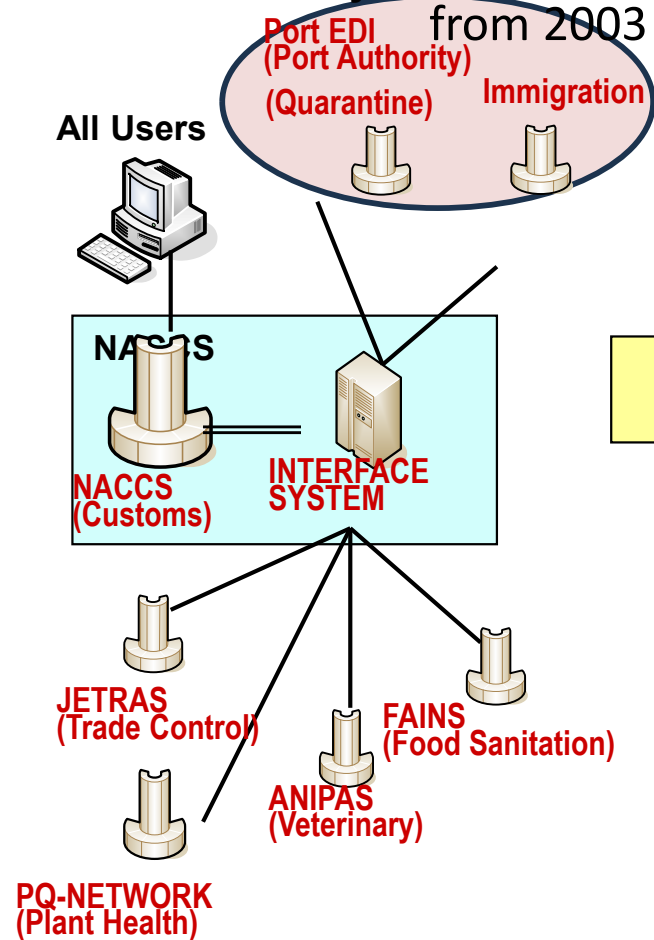

New Generation (From Oct. 2008)
Common Portal SW System
User Friendly

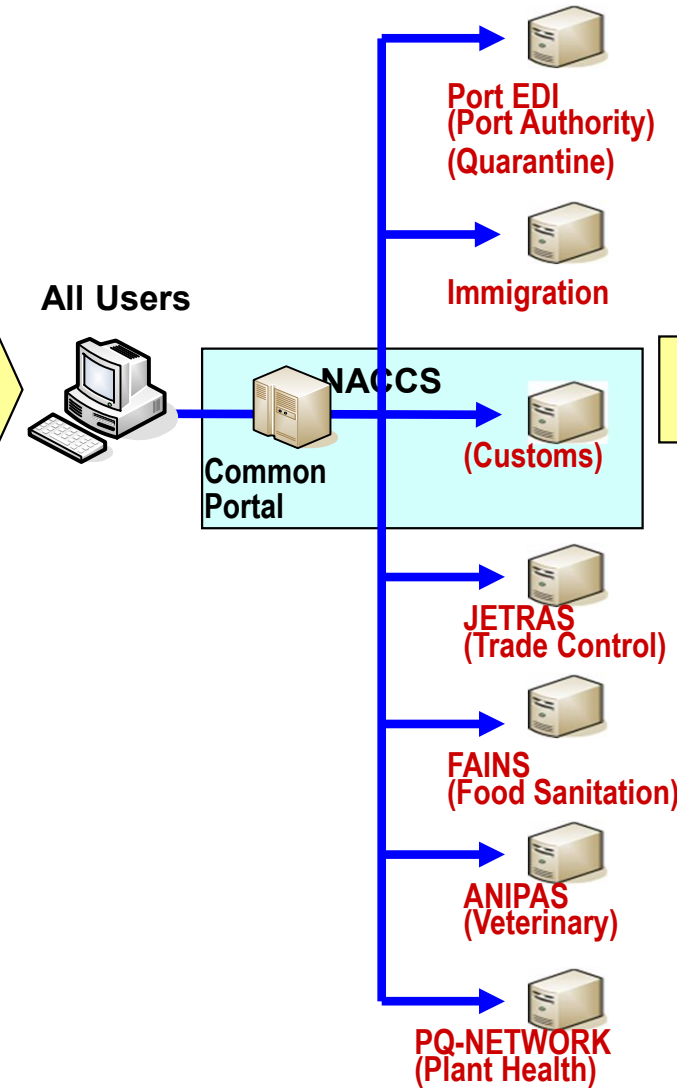

New Dimension (Partially from Oct. 2008 and complete by Oct. 2013)
Integrated NACCS
Very User Friendly, Less Cost

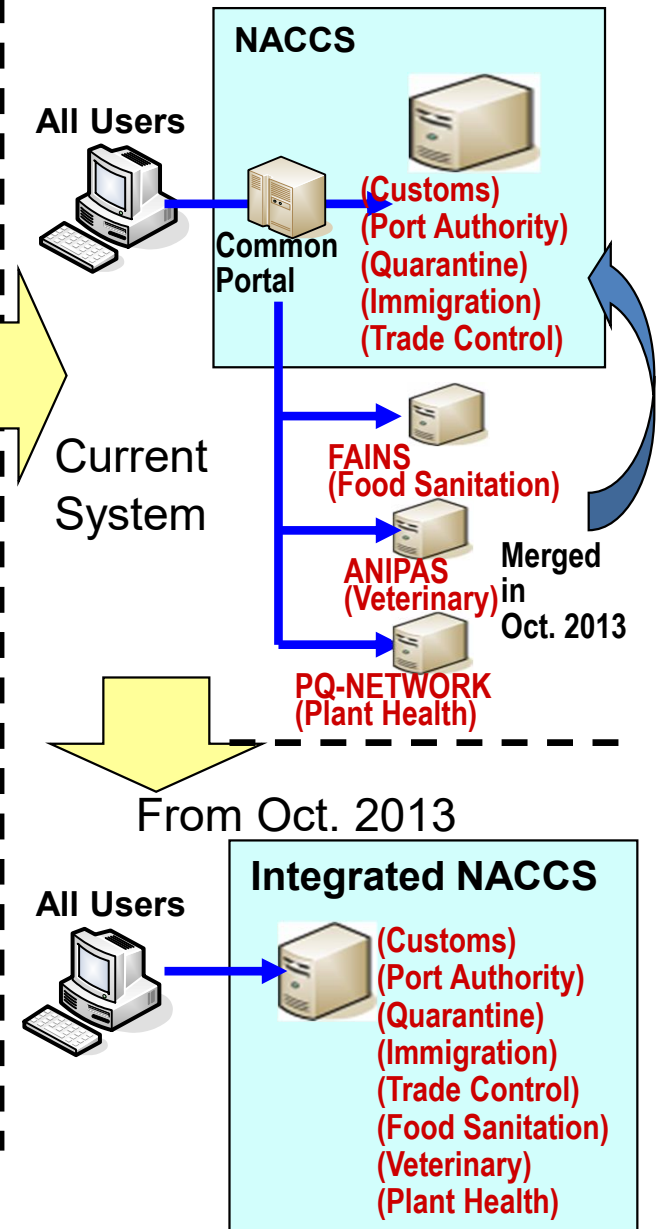

First Generation (From Apr. 1997, Jul. 2003)

Interfacing SW System

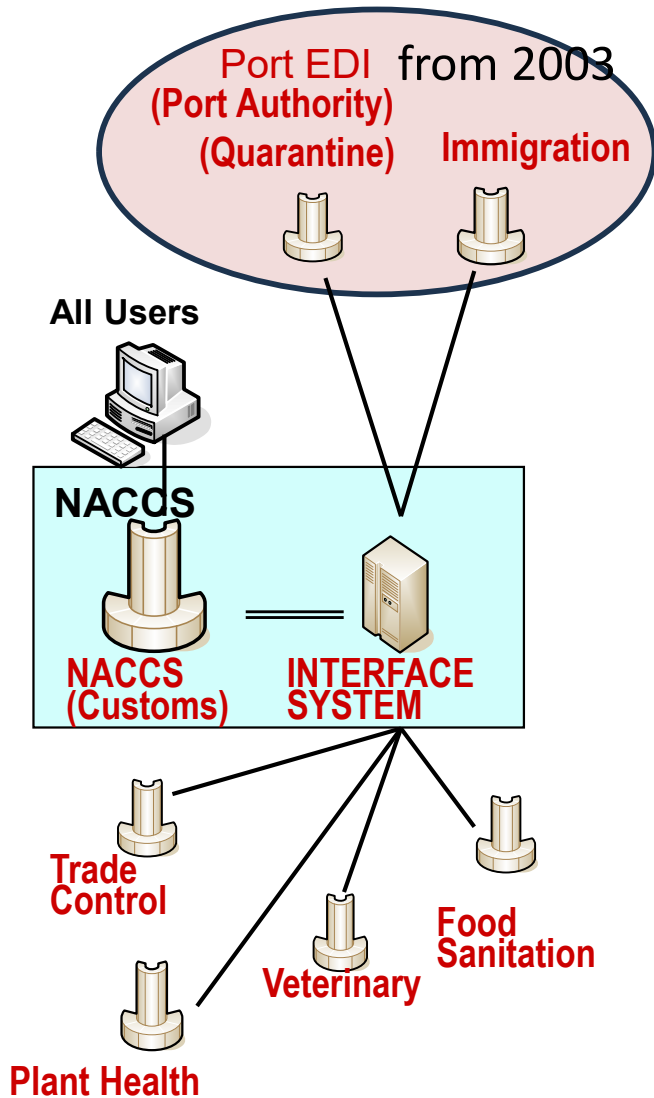

Although this SW system gives a basic benefit of SW to the users, it is not so user friendly compared with Common Portal SW.

A user is required to **obtain and manage multiple IDs and passwords** issued by individual Other Government Agency (OGA) systems, and to consult with **many help desks** if some difficulties occur.

Each OGA system is owned and operated by respective OGA.

More importantly, besides the benefit of SW function, interfacing Customs system with OGAs allows declarants to process customs procedure and OGAs **concurrently**.

Without the interfacing system, declarants are required to take OGA procedures first and then customs procedure at last as the customs is required to confirm all the necessary official requirements completed prior to the release. **This is a so-called "one by one process"**, which is much more time consuming than the concurrent process.

Next Generation (From Oct. 2008)

Common Portal SW System

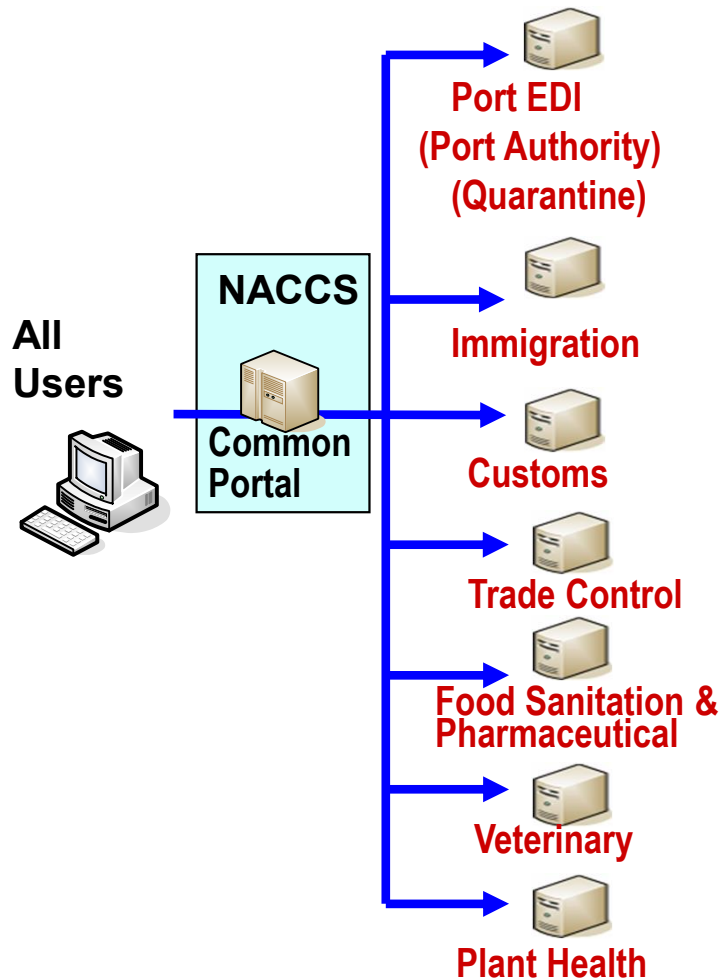

More User-Friendly System

A user is merely required to obtain and manage **one ID and password** issued by the Common Portal Administrator (NACCS Center), and to consult with Common Portal's **single help desk**.

Each OGA system is owned by respective OGA, but the daily system operation is managed by the administrator of the Common Portal (NACCS Center) because all queries on the system operation come to the help desk of the Common Portal.

Ultimate Solution (From Oct. 2013): Integrated NACCS



Very User-Friendly, Less Cost
Advantage of Common Portal Plus

- Less development cost by avoiding the duplication of hard and software
- Less system maintenance costs by the integration of hardware
- Quicker response due to the single system (No network between the systems)

Towards System Integration

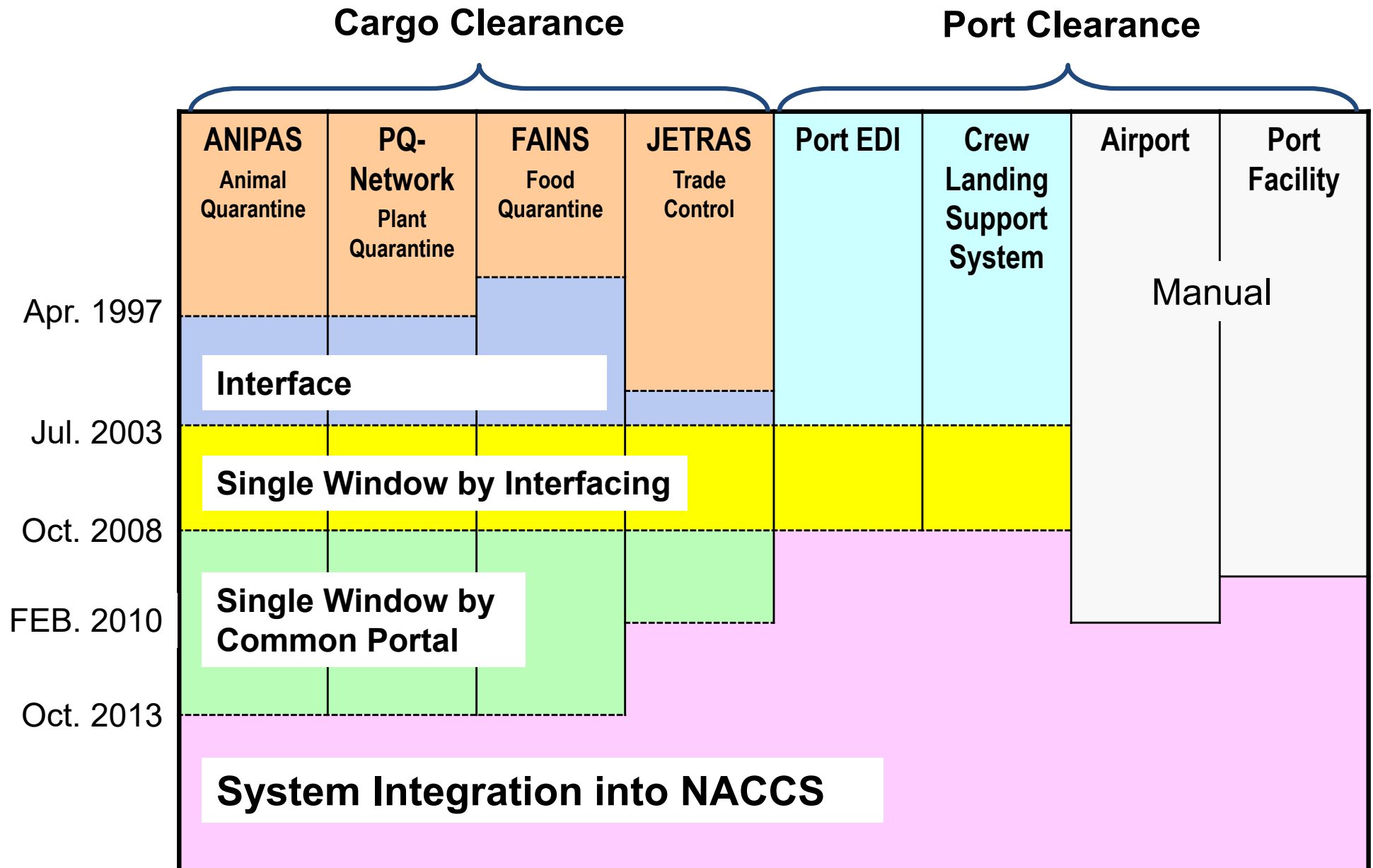

Number of Customs Procedures processed by NACCS and Ratio Processed by the System

Number of Export (thousand)

Manual
System (maritime)
System (air)
Ratio of System

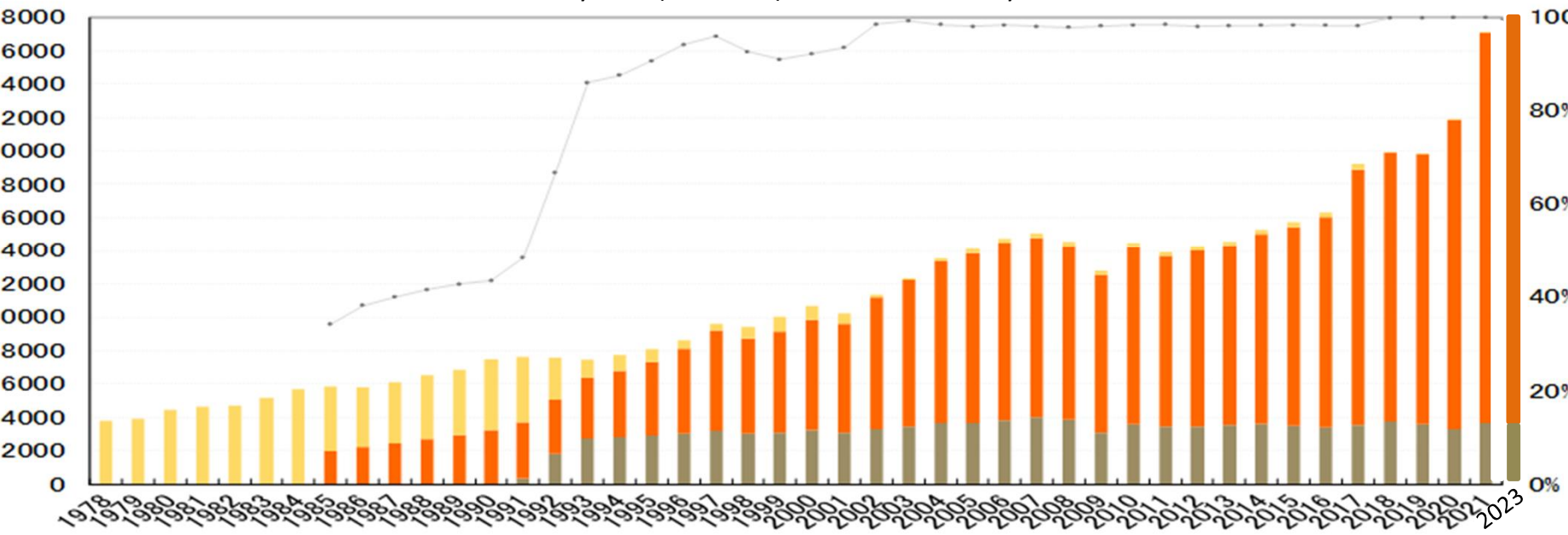

NACCS Export(A)
Air 27.3 million
Maritime 3.7 million
Total(B) 31 million
Ratio(A/B) 99%

Number of Import (thousand)

Ratio

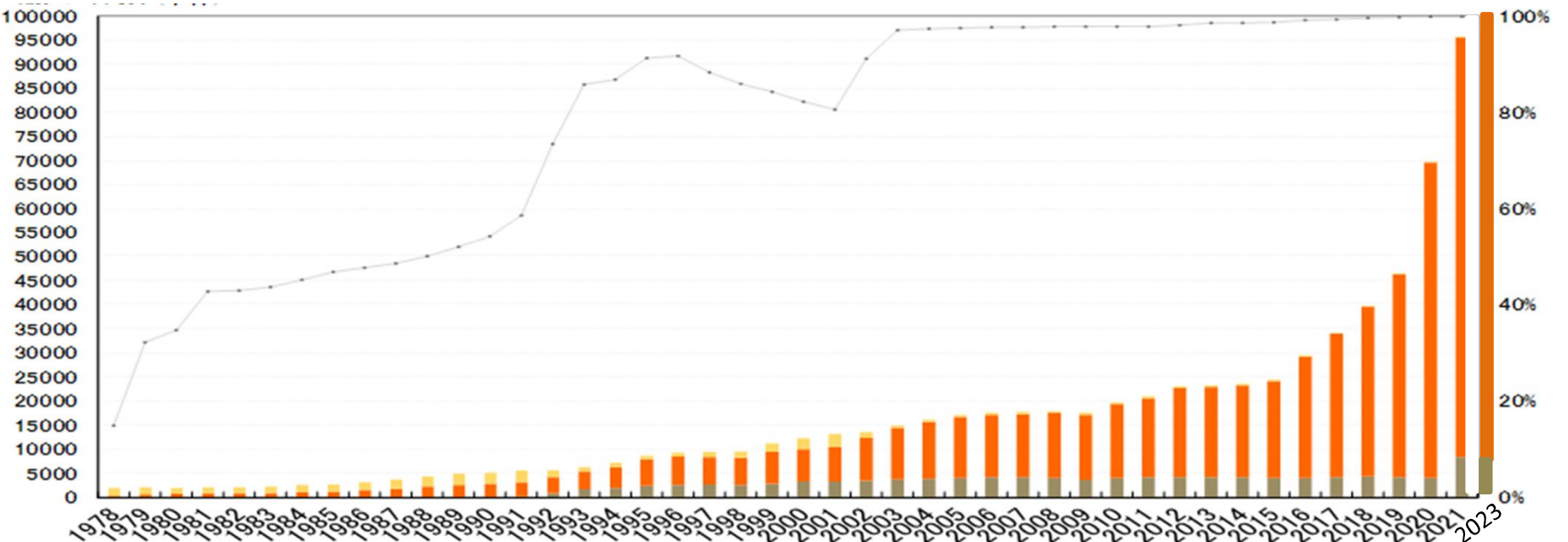

NACCS Import(A)
Air: 130 million
Maritime: 10 million
Total(B) 140 million
Ratio(A/B) 99%

NACCS Total(A)
Air: 157.3 million
Maritime: 13.8 million
Total(B) 171.1 million
Ratio(A/B) **99.9%**
(Year 2023)

System utilisation rate

24 hours per day, 7 days a week (other than planned system shutdown)

Fiscal year	Utilisation rate
2014	100%
2015	100%
2016	99.99%
2017	100%
2018	100%
2019	100%
2020	100%
2021	99.99%
2022	100%
2023	99.90%

Time Release Study

CHANGES IN THE MEANTIME REQUIRED FOR A TIME PERIOD FROM ARRIVAL TO RELEASE ON SEA CARGO

■ Arrival ~ Warehousing

■ Warehousing ~ Declaration

■ Declaration ~ Release

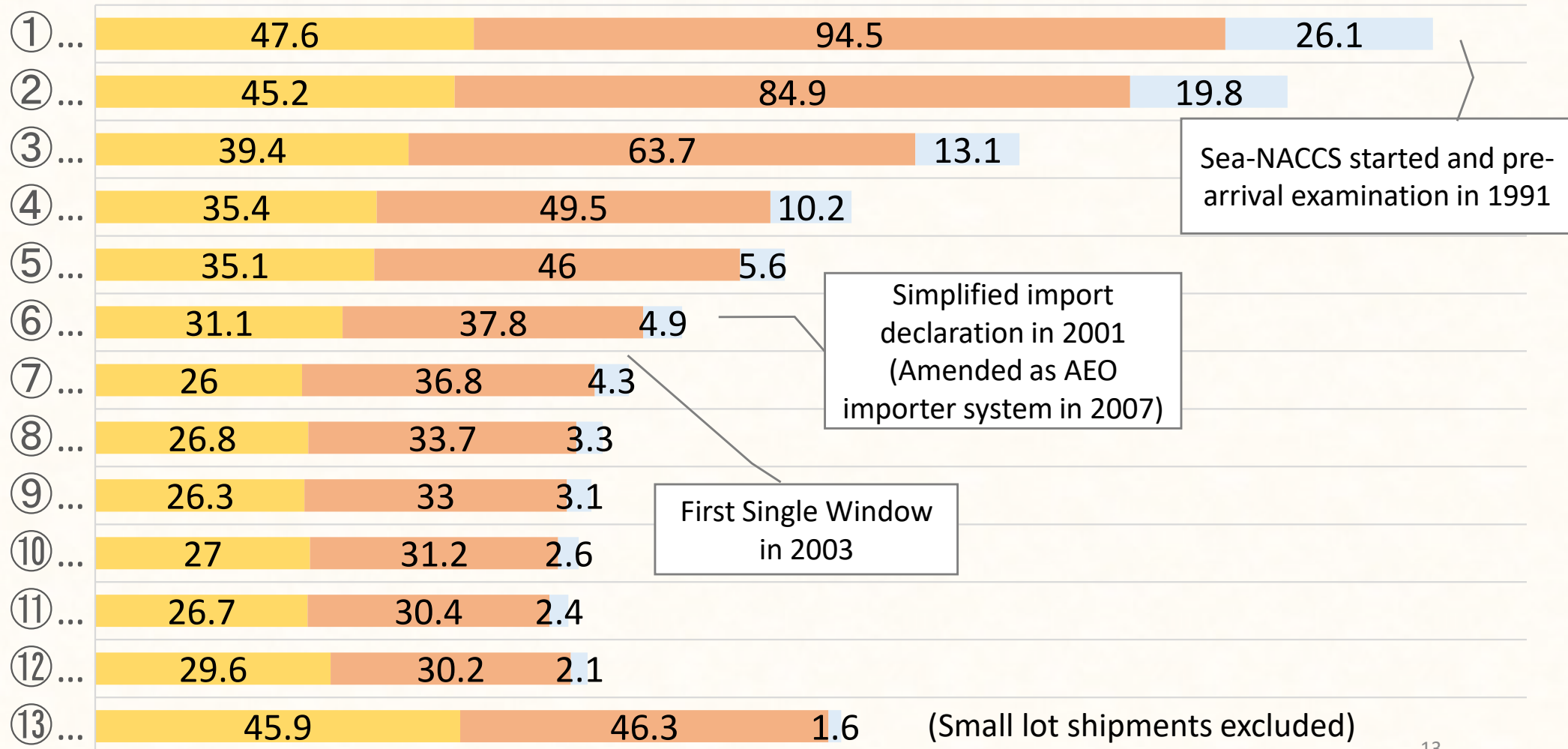

CHANGES IN THE MEANTIME REQUIRED FOR A TIME PERIOD FROM ARRIVAL TO RELEASE ON AIR CARGO

■ Arrival ~ Warehousing
 ■ Warehousing ~ Declaration
 ■ Declaration ~ Release

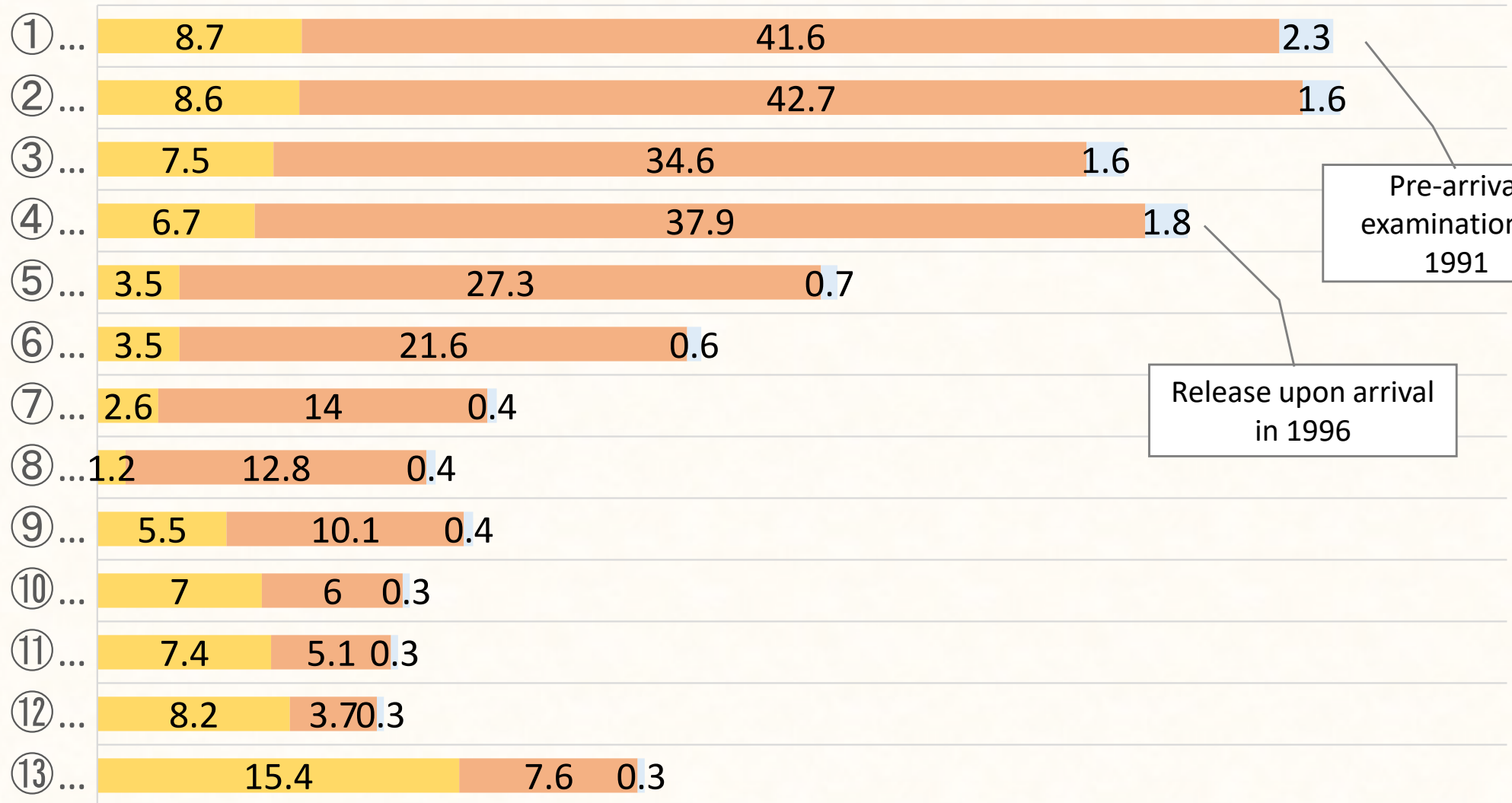

Pre-arrival examination in 1991

Release upon arrival in 1996

Challenges and way forward on Single Window

Digitalization of documents related to customs and trade

- Develop an environment to promote the digitalization of document and/or procedures through scanning of paper and OCR (Optical Character Recognition) of PDF documents

<Recent and Upcoming Projects>

- CO data exchange (Jun. 2023)
- Update of NACCS (Oct. 2025)
 - ✓ Update for responding rapidly increased e-commerce
 - ✓ Add new services

Take away

- Single window can be established step by step
- The goal is not to make a single window itself, but to facilitate import/export and other related procedures.
- It is essential to:
 - Analyse if procedures are necessary or not, and then analyse if procedures can be integrated
 - Effectively link systems
- Introduce stable system
- Training staff

Thank you

22 October 2024